



HAND-HELD DEVICES

Software Configuration Manual



HAND-HELD DEVICES

SOFTWARE CONFIGURATION MANUAL





DATALOGIC S.p.A.
Via Candini 2
40012 - Lippo di Calderara di Reno
Bologna - Italy

Hand-Held Devices

Ed.: 07/2004

This manual refers to the following software versions:

for Standard Architecture **SW 6.00** and later

for Enhanced Architecture **SW 2.07** and later

ALL RIGHTS RESERVED

Datalogic reserves the right to make modifications and improvements without prior notification.

Datalogic shall not be liable for technical or editorials errors or omissions contained herein, nor for incidental or consequential damages resulting from the use of this material.

Product names mentioned herein are for identification purposes only and may be trademarks and or registered trademarks of their respective companies.

© Datalogic S.p.A. 2002 - 2004

(Rev. B)

CONTENTS

	HOW TO USE THIS MANUAL	vi
1	INTRODUCTION	1
1.1	Status Indicators	2
2	INITIAL SETUP	3
2.1	Restore Default	3
2.2	Interface Selection	3
3	CONFIGURATION	8
	RS232 PARAMETERS	9
	Baud Rate	10
	Parity	11
	Data Bits	11
	Stop Bits	12
	Handshaking	12
	Ack/Nack Protocol	13
	Fifo	13
	Inter-character Delay	14
	Rx Timeout.....	14
	Serial Trigger Lock.....	15
	WEDGE PARAMETERS	16
	Keyboard Nationality.....	17
	Caps Lock.....	18
	Num Lock.....	18
	Inter-character Delay	19
	Inter-code Delay.....	19
	Keyboard Setting	20
	Control Character Emulation.....	22
	PEN EMULATION	23
	Operating Mode	24
	Minimum Output Pulse.....	25
	Conversion to Code 39	26
	Overflow.....	26
	Output Level.....	27
	Idle Level	27
	DATA FORMAT	28
	Code Identifier	31
	Custom Code Identifier	32

Header	33
Terminator.....	34
Field Adjustment	35
Field Adjustment Character	36
Code Length Tx	36
Character Replacement.....	37
POWER SAVE	39
Illuminator/Laser Driver.....	40
Sleep State	40
Enter Sleep Timeout	41
Standby.....	41
READING PARAMETERS	42
Trigger Type.....	43
Trigger Signal.....	43
Trigger-off Timeout	44
Flash Mode	44
Reads per Cycle	45
Safety Time.....	45
Beeper Intensity.....	46
Beeper Tone	46
Software Focus Level	47
Software Focus Range	48
DECODING PARAMETERS	49
Ink Spread	50
Overflow Control	50
Interdigit Control	51
Decoding Safety.....	51
Puzzle Solver™	52
CODE SELECTION	53
EAN/UPC Family	55
2/5 Family	59
Code 39 Family.....	60
Code 128 Family.....	62
Code 93	64
Codabar Family.....	65
Codablock-A	67
Codablock-F	67
MSI.....	68
Plessey	69
Telepen.....	70
Delta IBM	71
Code 11	72
Code 16K.....	73

	Code 49	73
	PDF417	74
	ADVANCED FORMATTING	75
	Concatenation	76
	Advanced Formatting	79
4	REFERENCES	94
4.1	RS232 Parameters	94
4.1.1	Handshaking	94
4.1.2	ACK/NACK Protocol	95
4.1.3	FIFO	95
4.1.4	RX Timeout	95
4.2	Pen Parameters	96
4.2.1	Minimum Output Pulse	96
4.2.2	Overflow	96
4.2.3	Output and Idle Levels	97
4.3	Data Format	98
4.3.1	Header/Terminator Selection	98
4.3.2	Set Custom Extended Header/Terminator Keys	99
4.4	Power Save	101
4.4.1	Illuminator/Laser Driver	101
4.4.2	Sleep State (<i>only devices with button/trigger</i>)	101
4.4.3	Enter Sleep Timeout	101
4.4.4	Standby (<i>only CCD devices with button/trigger</i>)	101
4.5	Reading Parameters	102
4.5.1	Trigger Signal	102
4.5.2	Trigger-Off Timeout	102
4.5.3	Reads per Cycle	102
4.5.4	Safety Time	103
4.6	Decoding Parameters	103
4.6.1	Ink-Spread	103
4.6.2	Overflow Control	103
4.6.3	Interdigit Control	103
4.7	Configuration Editing Commands	104
4.8	Configuration Copy Command	105
A	HOST CONFIGURATION STRINGS	106
B	CODE IDENTIFIER TABLE	117
C	HEX AND NUMERIC TABLE	121

HOW TO USE THIS MANUAL

Your reader is supplied with its own Quick Reference Manual which provides connection diagrams, reading diagrams, basic application parameter settings, default values, and specific technical features.

You can use either your reader's Quick Reference Manual or this Manual for initial configuration in order to set the default values and select the interface for your application.

This manual provides complete setup and configuration for your **Standard Architecture** and **Enhanced Architecture** readers. Since these two kinds of readers have different configuration and setup possibilities, the information in this manual is presented as follows:

- parameters not marked are valid for **both Standard and Enhanced Architecture** readers.
- parameters marked with (☀) are valid **only for Enhanced Architecture** readers.

If you are not sure if your reader is Standard or Enhanced Architecture, read the following code to check your software release:

transmit the Software release

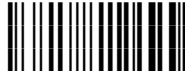

To use this manual for initial setup:

- 1) Read the Restore Default code on page 3.
- 2) Choose the correct interface selection code for your application from those listed in chapter 2.

If you wish to change the default settings, this manual provides complete configuration of your reader in an easy way.

To configure your reader:

- 1) Open the folded page in [Appendix C](#) with the hex-numeric table and keep it open during the device configuration.
- 2) Read the **Enter Configuration** code ONCE, available at the top of each page of configuration.
- 3) Modify the desired parameters in one or more sections following the procedures given for each group.
- 4) Read the **Exit and Save Configuration** code ONCE, available at the top of each page of configuration.

Reference notes describing the operation of the more complex parameters are given in chapter 4.

Sending Configuration Strings from Host

An alternative configuration method is provided in Appendix A using the RS232 interface. This method is particularly useful when many devices need to be configured with the same settings. Batch files containing the desired parameter settings can be prepared to configure devices quickly and easily.

Copy Command

A Master device (previously configured reader), can be used to send its configuration directly to other readers by connecting them together using two RS232 cables and reading the Copy Configuration command. See par. 4.8 for details.

1 INTRODUCTION

This manual provides all the necessary information for complete software configuration of various Datalogic families of **Hand-Held Devices**, (both Standard and Enhanced Architecture readers) including CCD guns and readers, laser scanners, and decoders.

Your reader contains a built-in decoder and multi-standard interface.

It is designed for use in a wide variety of applications and environments including **commercial**, **office automation**, **retail**, and **light industrial** applications where large quantities of information need to be collected rapidly, easily and reliably.

It has two status indicator functions which are described in the next paragraph.

1.1 STATUS INDICATORS

This reader has two indicators, LED and beeper. They signal several operating conditions which are described in the tables below.



POWER UP

Beeper	Meaning
L L L L	Parameters loaded correctly
H H H H long tones	Parameter loading error, reading or writing error in the non volatile memory
H L H L	Hardware error in EEPROM

CONFIGURATION

Beeper	Meaning
H H H H	correct entry or exit from Configuration mode
L	good read of a command
L L L	command read error

DATA ENTRY

Beeper	LED	Meaning
U	ON	correct read of a code in normal mode
 U long	ON	successful advanced format concatenation
U U U		timeout expired – operation not completed
 H long		error in advanced data formatting
	OFF	ready to read a code
H L long		tx buffer full (when FIFO is enabled)

U = user configurable tone

H = high tone

L = low tone

2 INITIAL SETUP

2.1 RESTORE DEFAULT

Read the restore default parameters code below.

Restore Default



2.2 INTERFACE SELECTION

Read the interface selection code for your application. Valid interface selections for your particular reader are also found in the relative Quick Reference Manual.

RS232

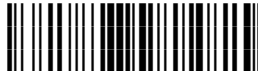

PEN



WEDGE

IBM AT or PS/2 PCs



IBM XT



PC Notebook



IBM SURE1

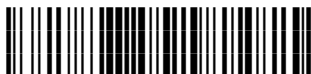

IBM Terminal 3153



WEDGE (continued)**IBM Terminals 31xx, 32xx, 34xx, 37xx:**

To select the interface for these IBM Terminals, read the correct KEY TRANSMISSION code. Select the KEYBOARD TYPE if necessary (default = advanced keyboard).

KEY TRANSMISSION MODE

make-only keyboard



make-break keyboard



KEYBOARD TYPE

◆ advanced keyboard



typewriter keyboard



WEDGE (continued)**ALT MODE** ☀

The ALT-mode selection allows barcodes sent to the PC to be interpreted correctly independently from the Keyboard Nationality used. **You do not need to make a Keyboard Nationality selection.**

(default = Num Lock Unchanged). **Make sure the Num Lock key on your keyboard is ON.**

IBM AT - ALT mode

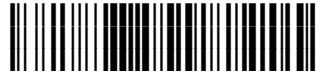

PC Notebook - ALT mode

**WYSE TERMINALS** ☀

ANSI Keyboard

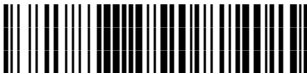

PC Keyboard



ASCII Keyboard

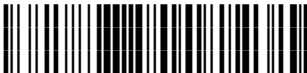

VT220 style Keyboard



WEDGE (continued)

DIGITAL TERMINALS 

VT2xx/VT3xx/VT4xx



APPLE 

APPLE ADB Bus



YOUR READER IS NOW READY TO READ BARCODES.

To change the defaults see Chapter 3.

3 CONFIGURATION

Once your reader is setup, you can change the default parameters to meet your application needs. Refer to chapter 2 for initial configuration in order to set the default values and select the interface for your application.

In this manual, the configuration parameters are divided into logical groups making it easy to find the desired function based on its reference group.

The first three groups are for Standard Interface parameter configuration:

- **RS232**
- **WEDGE**
- **PEN EMULATION**

The following parameter groups are common to all interface applications:

DATA FORMAT parameters regard the messages sent to the Host system for all interfaces except Pen Emulation.

POWER SAVE manages overall current consumption in the reading device.

READING PARAMETERS control various operating modes and indicator status functioning.

DECODING PARAMETERS maintain correct barcode decoding in certain special reading conditions.

CODE SELECTION parameters allow configuration of a personalized mix of codes, code families and their options.

ADVANCED FORMATTING PARAMETERS allow code concatenation and advanced formatting of messages towards the Host. It cannot be used with Pen Emulation.

RS232 PARAMETERS

⊙	BAUD RATE	⊙
⊙	PARITY	⊙
⊙	DATA BITS	⊙
⊙	STOP BITS	⊙
⊙	HANDSHAKING	⊙
⊙	ACK/NACK PROTOCOL	⊙
⊙	FIFO	⊙
⊙	INTER-CHARACTER DELAY	⊙
⊙	RX TIMEOUT	⊙
⊙	SERIAL TRIGGER LOCK	⊙

TO CHANGE THE DEFAULT VALUES

1. Read the **Enter Configuration** code ONCE, available at the top of each page.
2. Read configuration codes from the desired groups.
 -  = Read the code and follow the procedure given
 - ◆ = Default value
 - ★ = Only for Enhanced Architecture readers
3. Read the **Exit and Save Configuration** code ONCE, available at the top of each page.



BAUD RATE

150 baud



600 baud



2400 baud



◆ 9600 baud



38400 baud 



300 baud



1200 baud



4800 baud

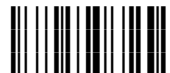

19200 baud

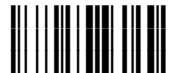



RS232



PARITY

◆ none



even parity



odd parity



DATA BITS

7 bits



◆ 8 bits



9 bits





STOP BITS

◆ 1 stop bit



2 stop bits



HANDSHAKING

◆ disable



hardware (RTS/CTS)



software (XON/XOFF)



RTS always ON



See par. 4.1.1 for details.



ACK/NACK PROTOCOL

◆ disable



enable



See par. 4.1.2 for details.

FIFO

disable



◆ enable



See par. 4.1.3 for details.



INTER-CHARACTER DELAY



delay between characters transmitted to Host



Read 2 numbers from the table where:

00 = DELAY disabled
01-99 = DELAY from **1** to **99** milliseconds

◆ delay disabled

RX TIMEOUT



timeout control in reception from Host



Read 2 numbers from the table where:

00 = TIMEOUT disabled
01-99 = TIMEOUT from **.1** to **9.9** seconds

◆ rx timeout 5 seconds

See par. 4.1.4 for details.



SERIAL TRIGGER LOCK

◆ disabled



enabled





Read 2 characters from the Hex/Numeric table where:



- First Character enables device trigger
- Second Character inhibits device trigger until the first character is received again.

Valid characters are in the range **00-7F** for Standard Architecture readers and **00-FE** for Enhanced Architecture readers.

WEDGE PARAMETERS

⊙	KEYBOARD NATIONALITY	⊙
⊙	CAPS LOCK	⊙
⊙	NUM LOCK 	⊙
⊙	INTER-CHARACTER DELAY	⊙
⊙	INTER-CODE DELAY	⊙
⊙	KEYBOARD SETTING 	⊙
⊙	CONTROL CHARACTER EMULATION	⊙

TO CHANGE THE DEFAULT VALUES

1. Read the **Enter Configuration** code ONCE, available at the top of each page.
2. Read configuration codes from the desired groups.
 -  = Read the code and follow the procedure given
 - ◆ = Default value
 -  = Only for Enhanced Architecture readers
3. Read the **Exit and Save Configuration** code ONCE, available at the top of each page.



KEYBOARD NATIONALITY

Belgian



English



French



German



Italian



Spanish



Swedish



◆ USA





CAPS LOCK

◆ caps lock OFF



caps lock ON



Select the appropriate code to match your keyboard caps lock status.

Note: For **PC Notebook** interface selections, the caps lock status is automatically recognized, therefore this command is not necessary.

NUM LOCK ☀

toggle num lock



◆ num lock unchanged



This selection is used together with the Alt Mode interface selection for AT or Notebook PCs.

It changes the way the Alt Mode procedure is executed, therefore it should be set as follows:

- if your keyboard Num Lock is normally on use **num lock unchanged**
- if your keyboard Num Lock is normally off use **toggle num lock**

In this way the device will execute the Alt Mode procedure correctly for your application.



INTER-CHARACTER DELAY



delay between characters transmitted to Host



Read 2 numbers from the table where:

00 = DELAY disabled
 01-99 = DELAY from 1 to 99 milliseconds

◆ delay disabled

INTER-CODE DELAY



delay between codes transmitted to Host



Read 2 numbers from the table where:

00 = DELAY disabled
 01-99 = DELAY from 1 to 99 seconds

◆ delay disabled



KEYBOARD SETTING **ALPHANUMERIC KEYBOARD SETTING**

The reader can be used with terminals or PCs with various keyboard types and nationalities through a simple keyboard setting procedure.

The type of computer or terminal must be selected before activating the keyboard setting command.

Keyboard setting consists of communicating to the reader how to send data corresponding to the keyboard used in the application. The keys must be set in a specific order.

Press and release a key to set it.

Some characters may require more than one key pressed simultaneously during normal use (refer to the manual of your PC or terminal for keyboard use). The exact sequence must be indicated to the reader in this case pressing and releasing the different keys.

Example:

If one has to press the "Shift" and "4" keys simultaneously on the keyboard to transmit the character "\$" to the video, to set the "\$", press and release "Shift" then press and release "4".

Each pressed and released key must generate an acoustic signal on the reader, otherwise repress the key. Never press more than one key at the same time, even if this corresponds to the normal use of your keyboard.

Press "Backspace" to correct a wrong key entry. In this case the reader emits 2 beeps.

Note: "CAPS LOCK" and "NUM LOCK" must be off before starting the keyboard setting procedure. "SHIFT" must be repressed for each character and cannot be substituted by "CAPS LOCK".



setting the alphanumeric keyboard



Read the code above.

Press the keys shown in the following table according to their numerical order:

WEDGE

Some ASCII characters may be missing as this depends on the type of keyboard: these are generally particular characters relative to the various national symbolologies. In this case:

- **The first 4 characters (Shift, Alt, Ctrl, and Backspace) can only be substituted with keys not used, or substituted with each other.**
- characters can be substituted with other single symbols (e.g. "SPACE") even if not included in the barcode set used.
- characters can be substituted with others corresponding to your keyboard.

The reader signals the end of the procedure with 2 beeps indicating the keys have been registered.

01 : Shift		
02 : Alt		
03 : Ctrl		
04 : Backspace		
05 : SPACE	28 : 7	51 : N
06 : !	29 : 8	52 : O
07 : "	30 : 9	53 : P
08 : #	31 : :	54 : Q
09 : \$	32 : ;	55 : R
10 : %	33 : <	56 : S
11 : &	34 : =	57 : T
12 : '	35 : >	58 : U
13 : (36 : ?	59 : V
14 :)	37 : @	60 : W
15 : *	38 : A	61 : X
16 : +	39 : B	62 : Y
17 : ,	40 : C	63 : Z
18 : -	41 : D	64 : [
19 : .	42 : E	65 : \
20 : /	43 : F	66 :]
21 : 0	44 : G	67 : ^
22 : 1	45 : H	68 : _ (underscore)
23 : 2	46 : I	69 : `
24 : 3	47 : J	70 : {
25 : 4	48 : K	71 :
26 : 5	49 : L	72 : }
27 : 6	50 : M	73 : ~
		74 : DEL



CONTROL CHARACTER EMULATION

◆ CTRL+ Shift + Key



CTRL + Key



PEN EMULATION

⊙	OPERATING MODE	⊙
⊙	MINIMUM OUTPUT PULSE	⊙
⊙	CONVERSION TO CODE 39	⊙
⊙	OVERFLOW	⊙
⊙	OUTPUT LEVEL	⊙
⊙	IDLE LEVEL	⊙

TO CHANGE THE DEFAULT VALUES

1. Read the **Enter Configuration** code ONCE, available at the top of each page.
2. Read configuration codes from the desired groups.
 - ◆ = Default value
 - ★ = Only for Enhanced Architecture readers
3. Read the **Exit and Save Configuration** code ONCE, available at the top of each page.

PEN EMULATION

The operating mode parameters are complete commands and do not require reading the Enter and Exit configuration codes.

OPERATING MODE

◆ interpret mode



Interprets commands without sending them to the decoder.

transparent mode



Sends commands to the decoder without interpreting them.



MINIMUM OUTPUT PULSE

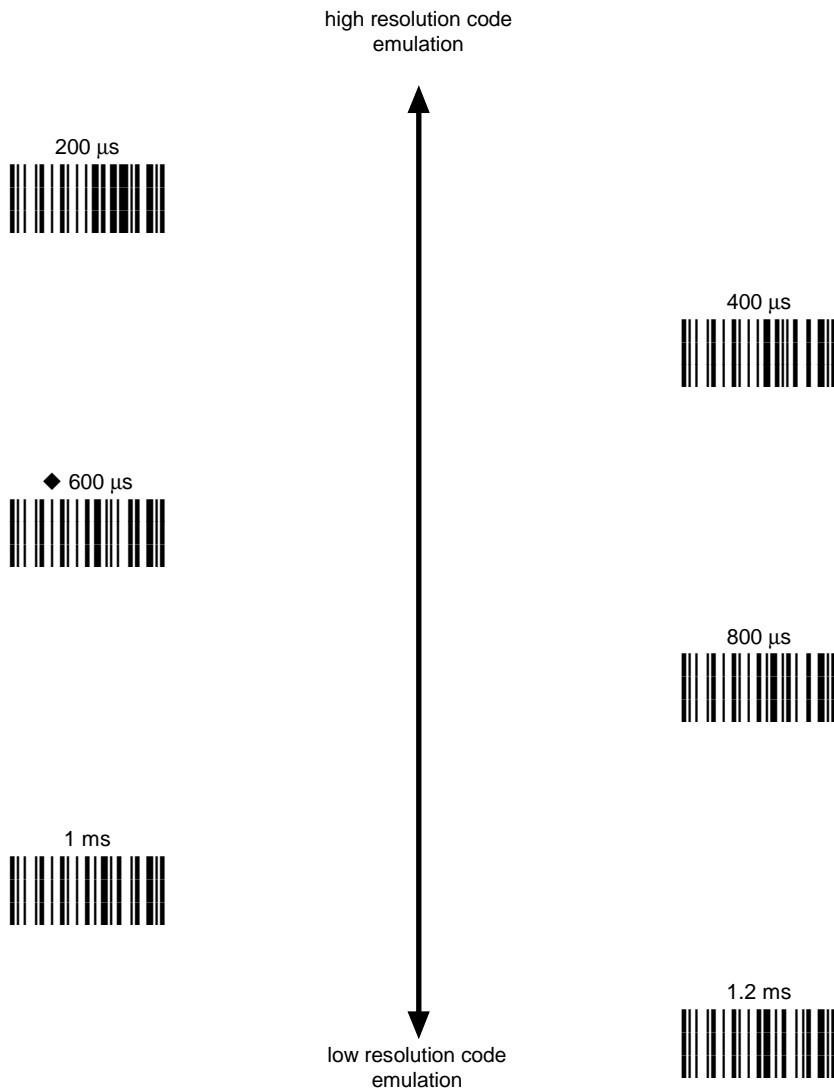

See par. 4.2.1 for details.



PEN EMULATION



CONVERSION TO CODE 39

◆ disable



Transmits codes in their original format.

enable



Converts codes read into Code 39 format.

☀ The following codes are ALWAYS converted into Code 39 format:
Codablock-A, Codablock-F Standard and EAN, MSI, Plessey,
Telepen, Delta IBM, Code 11, Code 16K, Code 49, PDF417

OVERFLOW

narrow



◆ medium



wide



See par. 4.2.2 for details.



OUTPUT LEVEL

◆ normal
(white = logic level 0)



inverted
(white = logic level 1)



See par. 4.2.3 for details.

IDLE LEVEL

◆ normal
(black level)



inverted
(white level)

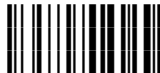

See par. 4.2.3 for details.

DATA FORMAT

NOT FOR PEN INTERFACES

⊙	CODE IDENTIFIER	⊙
⊙	CUSTOM CODE IDENTIFIER	⊙
⊙	HEADER	⊙
⊙	TERMINATOR	⊙
⊙	FIELD ADJUSTMENT ✨	⊙
⊙	FIELD ADJ. CHARACTER ✨	⊙
⊙	CODE LENGTH TX ✨	⊙
⊙	CHARACTER REPLACEMENT ✨	⊙

TO CHANGE THE DEFAULT VALUES

1. Read the **Enter Configuration** code ONCE, available at the top of each page.

2. Read configuration codes from the desired groups.



= Read the code and follow the procedure given



= Default value



= Only for Enhanced Architecture readers

3. Read the **Exit and Save Configuration** code ONCE, available at the top of each page.

DATA FORMAT

CODE IDENTIFIER TABLE			
CODE	AIM STANDARD	DATALOGIC STANDARD	Custom
2/5 interleaved]I y	N	
2/5 industrial]X y	P	
2/5 normal 5 bars]S y	O	
2/5 matrix 3 bars]X y	Q	
EAN 8]E 4	A	
EAN 13]E 0	B	
UPC A]X y	C	
UPC E]X y	D	
EAN 8 with 2 ADD ON]E 5	J	
EAN 8 with 5 ADD ON]E 6	K	
EAN 13 with 2 ADD ON]E 1	L	
EAN 13 with 5 ADD ON]E 2	M	
UPC A with 2 ADD ON]X y	F	
UPC A with 5 ADD ON]X y	G	
UPC E with 2 ADD ON]X y	H	
UPC E with 5 ADD ON]X y	I	
Code 39]A y	V	
Code 39 Full ASCII]A y	W	
CODABAR]F y	R	
ABC CODABAR]X y	S	
Code 128]C y	T	
EAN 128]C y	k	
☀ ISBT 128]C4	f	
Code 93]G y	U	
CIP/39]X y	Y	
CIP/HR]X y	e	
Code 32]X y	X	
☀ Codablock-A]O 6	n	
☀ Codablock-F Std]O 4	l	
☀ Codablock-F EAN]O 5	m	
☀ MSI]M y	Z	
☀ Plessey Standard]P 0	a	
☀ Plessey Anker]P 1	o	
☀ Telepen]X 0	d	
☀ Delta IBM]X 0	c	
☀ Code 11]H y	b	
☀ Code 16K]K 0	p	
☀ Code 49]T y	q	
☀ PDF417]X 0	r	

DATA FORMAT

- AIM standard identifiers are not defined for all codes: the X identifier is assigned to the code for which the standard is not defined. The y value depends on the selected options (check digit tested or not, check digit tx or not, etc.).
- When customizing the Datalogic Standard code identifiers, 1 or 2 identifier characters can be defined for each code type. If only 1 identifier character is required, the second character must be selected as **FF** (disabled).
- The code identifier can be singly disabled for any code by simply selecting **FF** as the first identifier character.
- Write in the Custom character identifiers in the table above for your records.



DATA FORMAT



CODE IDENTIFIER

◆ disable



Datalogic standard



AIM standard



custom





CUSTOM CODE IDENTIFIER

define custom code identifier(s)



- ① Read the above code.
(Code Identifiers default to Datalogic standard, see table on previous page).
- ② Select the code type from the code table in Appendix B for the identifier you want to change.
- ③ You can define 1 or 2 identifier characters for each code type. If only 1 identifier character is required, the second character must be selected as **FF** (disabled). Read the hexadecimal value corresponding to the character(s) you want to define as identifiers for the code selected in step ②: valid characters are in the range **00-7F** for Standard Architecture readers and **00-FE** for Enhanced Architecture readers.

Example: To define Code 39 Code Identifier = @

Read  +  + 40 + FF



HEADER

no header



one character header



two character header



three character header



four character header



five character header



six character header



seven character header



eight character header



After selecting **one** of the desired Header codes, read the character(s) from the HEX table.

Example:



+ 41 + 42 + 43 + 44 = Header **ABCD**

For more details see par. 4.3.1.



DATA FORMAT



TERMINATOR

no terminator



one character terminator



two character terminator



three character terminator



four character terminator



five character terminator



six character terminator



seven character terminator

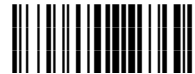

eight character terminator



After selecting **one** of the desired Terminator codes, read the character(s) from the HEX table.

Example:

two character terminator

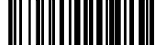

+ 0D + 0A = Terminator CR LF

For more details see par. 4.3.1.

**FIELD ADJUSTMENT** 

not valid for
PDF417 codes

◆ disable field adjustment



Field adjustment allows a number of characters n , to be added to or subtracted from the barcode read. The adjustment can be different for each enabled code type. To define the field adjustment:

- ① Read the enable field adjustment code:



- ② Select the code type from the Code Identifier Table in Appendix B.

- ③ Select the type of adjustment to perform:

right addition



left addition



right deletion



left deletion



- ④ Read a number in the range **01 - 32** from the Hex/Numeric Table to define how many characters to add or delete:

Conditions:

- Adjustment is only performed on the barcode data, the Code Identifier and Code Length Transmission fields are not modified by the field adjustment parameter.
- If the field setting would subtract more characters than exist in the barcode, the subtraction will take place only to code length 0.
- You can set up to a maximum of 10 different field adjustments on the same barcode family or on different barcode families.

**DATA FORMAT**

Example: To add 4 characters to the right of Standard Code 39 Codes:

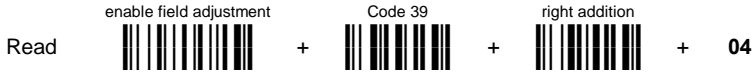
**FIELD ADJUSTMENT CHARACTER** 

- ① Read the field adjustment character code:

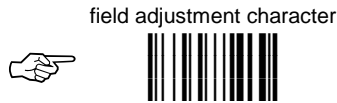

- ② Read the hexadecimal value corresponding to the character you want to use for field adjustment. Valid characters are in the range **00-FE**.

Example:

To define the field adjustment character = **A**:

**CODE LENGTH TX** 

code length transmitted



◆ code length not transmitted



code length transmitted in 4-digit format



The code length is transmitted in the message after the Headers and Code Identifier characters. The code length is calculated after performing any field adjustment operations.

**CHARACTER REPLACEMENT** 

not valid for
PDF417 codes

◆ disable character replacement



This parameter allows up to three characters to be replaced from the barcode read. These substitutions are stored in memory. To define each character replacement:

- ① Read one of the following character replacement codes:



first character replacement



second character replacement



third character replacement



- ② From the Code Identifier Table in Appendix B, read the Code Identifier for the desired code family.
0 = character replacement will be effective for all code families.
- ③ From the Hex/Numeric Table read two characters corresponding to the Hex value (**00-FE**) which identifies the character to be replaced.
- ④ From the Hex/Numeric Table read two characters corresponding to the Hex value (**00-FE**) which identifies the new character to replace.
FF = the character to be replaced will be substituted with no character, that is, it will be removed from the code.

**Example:**

The following strings define:

1. *First Character Replacement:* substitution in *Code 39 barcodes* of all occurrences of the **0** character with the **1** character.
2. *Second Character Replacement:* substitution in *Code 39 barcodes* of all occurrences of the **A** character with the **B** character.

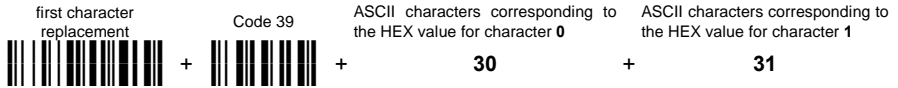

For Code 39 codes containing the string "0123", the contents transmitted will be "1123".

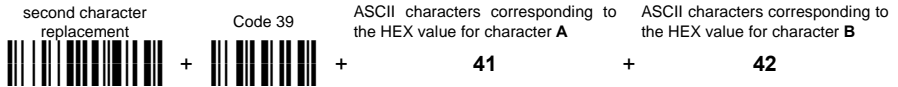

For Code 39 codes containing the string "ABCD", the contents transmitted will be "BBCD".

POWER SAVE

⊙	ILLUMINATOR/LASER DRIVER	⊙
⊙	SLEEP STATE	⊙
⊙	ENTER SLEEP TIMEOUT	⊙
⊙	STANDBY	⊙

TO CHANGE DEFAULT VALUES

1. Read the **Enter Configuration** code ONCE, available at the top of each page.

2. Read configuration codes from the desired groups.



= Read the code and follow the procedure given



= Default value

3. Read the **Exit and Save Configuration** code ONCE, available at the top of each page.



POWER SAVE



ILLUMINATOR/LASER DRIVER

no change before beep



off before beep

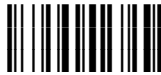

See par. 4.4.1 for details.

SLEEP STATE

ONLY DEVICES WITH BUTTON/TRIGGER

◆ disable



enable



See par. 4.4.2 for details.



POWER SAVE

ENTER SLEEP TIMEOUT

ONLY DEVICES WITH BUTTON/TRIGGER



enter sleep timeout



Read 2 numbers in the range 00-99:

- 00 = Enter Sleep state immediately
- 01-99 = corresponds to a max. 9.9 sec. delay before entering the Sleep state.

See par. 4.4.3 for details.

STANDBY

ONLY DEVICES WITH BUTTON/TRIGGER

◆ disable



optimize for reading speed

enable



optimize for low power consumption

See par. 4.4.4 for details.

READING PARAMETERS

⊙	<i>TRIGGER TYPE</i>	⊙
⊙	<i>TRIGGER SIGNAL</i>	⊙
⊙	<i>TRIGGER-OFF TIMEOUT</i>	⊙
⊙	<i>FLASH MODE</i>	⊙
⊙	<i>READS PER CYCLE</i>	⊙
⊙	<i>SAFETY TIME</i>	⊙
⊙	<i>BEEPER INTENSITY</i>	⊙
⊙	<i>BEEPER TONE</i>	⊙
⊙	<i>SOFTWARE FOCUS LEVEL</i>	⊙
⊙	<i>SOFTWARE FOCUS RANGE</i>	⊙

TO CHANGE DEFAULT VALUES

1. Read the **Enter Configuration** code ONCE, available at the top of each page.

2. Read configuration codes from the desired groups.



= Read the code and follow the procedure given



= Default value

3. Read the **Exit and Save Configuration** code ONCE, available at the top of each page.



READING PARAMETERS



TRIGGER TYPE

ONLY DEVICES WITH BUTTON/TRIGGER

hardware trigger



Restore Trigger Mode

software trigger



Enables "FLASH" MODE
for trigger version

TRIGGER SIGNAL

ONLY DEVICES WITH BUTTON/TRIGGER

trigger active level



trigger active pulse



See par. 4.5.1 for details



READING PARAMETERS

TRIGGER-OFF TIMEOUT

ONLY DEVICES WITH BUTTON/TRIGGER



trigger-off timeout



Read 2 numbers in the range 00-99:

- 00 = disables the trigger-off timeout
- 01-99 = corresponds to a max. 99-sec. delay after the trigger press to allow the reader to turn off automatically.

◆ trigger-off timeout disabled

See par. 4.5.2 for details.

FLASH MODE



"FLASH" ON duration



"FLASH" OFF duration



Read 2 numbers in the range 01-99:

01 to 99 = from .1 to 9.9 seconds.

◆ Flash-ON = 1 sec. Flash-OFF = 0.6 sec



READS PER CYCLE

◆ one read per cycle



multiple reads per cycle



See par. 4.5.3 for details.

SAFETY TIME

safety time

Limits same code consecutive reading.**Read 2 numbers in the range 00-99:**

00 = no same code consecutive reading until reader is removed (no decoding) for at least 400 ms.

01 to 99 = timeout from .1 to 9.9 seconds before a consecutive read on same code.

◆ safety time = 0.5 sec

See par. 4.5.4 for details.



BEEPER INTENSITY

beeper off



low intensity



medium intensity



◆ high intensity



BEEPER TONE

tone 1

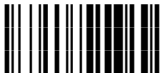

◆ tone 2



tone 3



tone 4





SOFTWARE FOCUS LEVEL**CCD Contact Readers ONLY**

factory focus level

high
resolution
codes

high resolution



med-high resolution



med-low resolution



low resolution

poor
quality
codes

- 1) The factory focus level is sufficient for almost all reading cases.
- 2) Reading time may be improved in your application by setting a fixed focus level. For example in cases where labels are of poor quality or are produced by a pin printer, select low resolution.



READING PARAMETERS



SOFTWARE FOCUS RANGE

CCD Long Range Readers ONLY

factory focus range



long range only



- 1) The factory focus range is sufficient for almost all reading cases.
 - 2) Reading time may be improved in your application by setting long range only. This selection also eliminates the “double blinking effect”.

DECODING PARAMETERS

⊙	INK SPREAD	⊙
⊙	OVERFLOW CONTROL	⊙
⊙	INTERDIGIT CONTROL	⊙
⊙	DECODING SAFETY	⊙
⊙	PUZZLE SOLVER™	☀ ⊙



CAUTION

Before changing these parameter values read the descriptions in par. 4.6.

TO CHANGE THE DEFAULT VALUES

1. Read the **Enter Configuration** code ONCE, available at the top of each page.
2. Read configuration codes from the desired groups.
 - ◆ = Default value
 - ☀ = Only for Enhanced Architecture readers
3. Read the **Exit and Save Configuration** code ONCE, available at the top of each page.



DECODING PARAMETERS



INK SPREAD

disable



◆ enable



See par. 4.6.1 for details.

OVERFLOW CONTROL

disable



◆ enable



See par. 4.6.2 for details.



DECODING PARAMETERS



INTERDIGIT CONTROL

disable



◆ enable



See par. 4.6.3 for details.

DECODING SAFETY

◆ one read



(decoding safety disabled)

three reads



two reads



four reads



Required number of good reads before accepting code.

**PUZZLE SOLVER™** 

◆ disable



enable



In the case of damaged or poorly printed codes, this parameter allows reading multiple parts of the single code to reconstruct it.

To read codes using this technology, simply move the reader over the code so that each line of the code is scanned.

Conditions:

- This parameter is only valid for the following codes:

EAN 8 without Add-on	EAN 13 without Add-on	UPC A without Add-on
Code 128	Code 39	

- Codablock-A and Codablock-F codes are automatically disabled.
- For Code 39, Check digit control without transmission is forced.
- PuzzleSolver™ is disabled when code ISBT 128 is enabled.

CODE SELECTION

⊙	EAN/UPC FAMILY		⊙
⊙	2/5 FAMILY		⊙
⊙	CODE 39 FAMILY		⊙
⊙	CODE 128 FAMILY		⊙
⊙	CODABAR FAMILY		⊙
⊙	CODE 93		⊙
⊙	CODABLOCK-A	☀	⊙
⊙	CODABLOCK-F	☀	⊙
⊙	MSI	☀	⊙
⊙	PLESSEY	☀	⊙
⊙	TELEPEN	☀	⊙
⊙	DELTA IBM	☀	⊙
⊙	CODE 11	☀	⊙
⊙	CODE 16K	☀	⊙
⊙	CODE 49	☀	⊙
⊙	PDF417	☀	⊙
	PDF READERS ONLY		

TO CHANGE THE DEFAULT VALUES

1. Read the **Enter Configuration** code ONCE, available at the top of each page.
2. Read configuration codes from the desired groups.
 -  = Read the code and follow the procedure given
 - ◆ = Default value
 - ☀ = Only for Enhanced Architecture readers
3. Read the **Exit and Save Configuration** code ONCE, available at the top of each page.



DISABLES ALL CODE FAMILIES

**NOTE**

The reader allows up to 5 code selections. This does not limit the number of CODES enabled to 5, as it depends on the code family.

SINGLE SELECTIONS =

- **ONE** combination code from the EAN family
- **ONE** code from the 2/5 family

Example

5 code selections:

1. **2/5 Interleaved**
2. **2/5 Industrial**
3. Code 128 + EAN 128
4. Code 39 Full ASCII + Code 32
5. **UPC A/UPC E**

In this section all **SINGLE** code selections are **underlined and in bold.**



CODE SELECTION



EAN/UPC FAMILY

disable the family



① Read the desired family code

Note:

Since the EAN/UPC without ADD ON code selection is enabled by default, to correctly enable another selection, first disable the family.

EAN 8/EAN 13/UPC A/UPC E with and without ADD ON



WITHOUT ADD ON

◆ EAN 8/EAN 13/UPC A/UPC E



EAN 8/EAN 13



UPC A/UPC E





CODE SELECTION

WITH ADD ON 2 AND 5

EAN 8/EAN 13/UPC A/UPC E



EAN 8/EAN 13



UPC A/UPC E



WITH ADD ON 2 ONLY

EAN 8/EAN 13



UPC A/UPC E



WITH ADD ON 5 ONLY

EAN 8/EAN 13



UPC A/UPC E





CODE SELECTION

EAN/UPC CHECK DIGIT TX SELECTIONS

For each code type in this family you can choose to transmit the check digit or not

CHECK DIGIT TRANSMISSION

EAN 8



EAN 13



UPC A

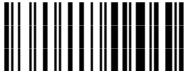

UPC E



NO CHECK DIGIT TRANSMISSION

EAN 8



EAN 13



UPC A



UPC E





CODE SELECTION



CONVERSION OPTIONS

UPC E to UPC A conversion



UPC E to EAN 13 conversion



UPC A to EAN 13 conversion

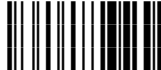

EAN 8 to EAN 13 conversion



Enable only ISBN conversion



Enable only ISSN conversion

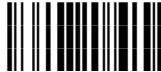

Enable both ISBN and ISSN conversion



Disable both ISBN and ISSN conversion

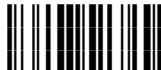



CODE SELECTION

2/5 FAMILY

disables the family



① Read the desired family code

◆ **Interleaved 2/5**



Normal 2/5 (5 Bars)



Industrial 2/5 (IATA)



Matrix 2/5 (3 Bars)

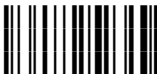

② Read a check digit selection

CHECK DIGIT TABLE

no check digit control



◆ check digit control and transmission



check digit control without transmission



③ Read 4 numbers for the code length where:

- **First 2 digits** = minimum code length.
- **Second 2 digits** = maximum code length.

The maximum code length is **99** characters.

The minimum code length must always be less than or equal to the maximum.

Examples:

0199 = variable from 1 to 99 digits in the code.

1010 = 10 digit code length only.

The pharmaceutical code below is part of the 2/5 family but has no check digit or code length selections.

Code CIP/HR



French pharmaceutical code



CODE SELECTION

CODE 39 FAMILY

disables the family



① Read the desired family code

② Read a check digit selection

◆ **Standard Code 39**



CHECK DIGIT TABLE

◆ no check digit control



◆ **Full ASCII Code 39**



check digit control
and transmission



check digit control
without transmission





CODE SELECTION

The pharmaceutical codes below are part of the Code 39 family but have no check digit selections.

Code CIP39

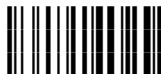

French pharmaceutical code

Code 32



Italian pharmaceutical code

CODE LENGTH (optional)

The code length selection is valid for the entire Code 39 family

Read the code + 4 numbers for the code length where:

First 2 digits = minimum code length.

Second 2 digits = maximum code length.

set code length



The maximum code length is **99** characters.

The minimum code length must always be less than or equal to the maximum.

Examples: **0199** = variable from 1 to 99 digits in the code. **1010** = 10 digit code length only.



CODE SELECTION



CODE 128 FAMILY

disables the family



① Read the desired family code

◆ Code 128



control without transmission
of check digit

EAN 128



control without transmission
of check digit

ISBT 128



- Enabling ISBT 128 automatically disables Puzzle Solver™.



CODE SELECTION



DEFINE EAN 128 SEPARATOR CHARACTER

Code EAN 128 uses a special character to separate a variable length code field from the next code field. The standard value of this character (from code EAN 128 specifications) is ASCII <GS> which is not useful for the Wedge and RS232 interface. For this reason it can be modified by the user:

GS substitution character



After selecting the code, read one character from the HEX table.

Valid range of characters for RS232 Interface = **00-7F**

Valid range of characters for WEDGE Interface = **00-9B**

**NOTE**

For Enhanced Architecture readers refer to the Character Replacement parameter in Data Format to manage the GS separator character.

EAN 128 SEPARATOR CHARACTER

- ◆ GS substitution character disabled



GS substitution character enabled

**NOTE**

For Enhanced Architecture readers refer to the Character Replacement parameter in Data Format to manage the GS separator character.



CODE SELECTION

TRANSMIT GS BEFORE CODE

Code EAN 128 uses the ASCII <GS> character to separate a variable length code field from the next code field. This character can also be transmitted before the code.

◆ disabled



enabled



If the <GS> character has been modified and enabled, (see previous paragraph), the new character will be transmitted by this command.

CODE 93

◆ disables the code



Code 93



control without transmission
of check digit



CODE SELECTION

CODABAR FAMILY

◆ disables the family



① Read the desired equality control code

② Read a start/stop transmission selection

Standard Codabar



no start/stop character equality control

START/STOP CHARACTER TRANSMISSION

no transmission



Standard Codabar



start/stop character equality control

transmission



The Codabar ABC code below uses a fixed start/stop character transmission selection.

Codabar ABC



no start/stop character equality control but transmission.



CODE SELECTION

Codabar ABC Forced Concatenation

enable Codabar ABC with forced concatenation



no start/stop character equality control but transmission

CODE LENGTH (optional)

The code length selection is valid for the entire Codabar family

Read the code + 4 numbers for the code length where:

First 2 digits = minimum code length.

Second 2 digits = maximum code length.

set code length



The maximum code length is **99** characters.

The minimum code length must always be less than or equal to the maximum.

Examples: **0199** = variable from 1 to 99 digits in the code. **1010** = 10 digit code length only.

START/STOP CHARACTER CASE IN TRANSMISSION

The start/stop character case selections below are valid for the entire Codabar family:

transmit start/stop characters in lower case



transmit start/stop characters in upper case





CODE SELECTION



CODABLOCK-A

- ◆ disables the code



Codablock-A

**Notes:**

- Enabling Codablock-A automatically disables the entire Code 39 family and vice-versa.
- Enabling Codablock-A automatically disables Puzzle Solver™.

To read stacked codes, simply move the reader over the code so that each line of the code is scanned. During this process a series of brief "ticks" indicates that reading is proceeding correctly.

CODABLOCK-F

- ◆ disables the family

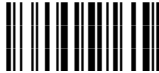

Codablock-F Standard

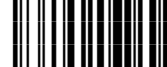

Codablock-F EAN

**Notes:**

- Enabling Codablock-F automatically disables Puzzle Solver™.

To read stacked codes, simply move the reader over the code so that each line of the code is scanned. During this process a series of brief "ticks" indicates that reading is proceeding correctly.



CODE SELECTION



◆ disables the family



Enable the code by selecting one of the check digit selections.

no check digit control



MOD10 check digit control
no check digit transmission

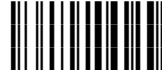

MOD10 check digit control
check digit transmission



MOD11 - MOD10 check digit control
no check digit transmission



MOD11 - MOD10 check digit control
check digit transmission



MOD10 - MOD10 check digit control
no check digit transmission



MOD10 - MOD10 check digit control
check digit transmission





CODE SELECTION

PLESSEY

◆ disables the family



Enable the code by selecting one of the check digit selections.

Standard Plessey

no check digit control



check digit control
check digit transmitted



check digit control
check digit not transmitted



Anker Plessey

no check digit control



check digit control
check digit transmitted



check digit control
check digit not transmitted





CODE SELECTION

TELEPEN

◆ disables the family



Enable the code by selecting one of the check digit selections.

Numeric Telepen

no check digit control



check digit control
check digit transmitted



check digit control
check digit not transmitted



Alphanumeric Telepen

no check digit control



check digit control
check digit transmitted



check digit control
check digit not transmitted





CODE SELECTION



DELTA IBM 

◆ disables the family



Enable the code by selecting one of the check digit selections.

no check digit control



Type 1 check digit control



Type 2 check digit control





CODE SELECTION



CODE 11

◆ disables the family



Enable the code by selecting one of the check digit selections.

no check digit control



Type C check digit control
check digit transmitted



Type C check digit control
check digit not transmitted



Type K check digit control
check digit transmitted



Type K check digit control
check digit not transmitted



Type C and Type K
check digit control
check digits transmitted



Type C and Type K
check digit control
check digits not transmitted





CODE SELECTION



CODE 16K

◆ disables the code



Code 16K



To read stacked codes, simply move the reader over the code so that each line of the code is scanned. During this process a series of brief "ticks" indicates that reading is proceeding correctly.

CODE 49

◆ disables the code



Code 49



To read stacked codes, simply move the reader over the code so that each line of the code is scanned. During this process a series of brief "ticks" indicates that reading is proceeding correctly.



CODE SELECTION



PDF417

Only PDF417 series readers

disables the code



◆ PDF417



To read stacked codes, simply move the reader over the code so that each line of the code is scanned. During this process a series of brief "ticks" indicates that reading is proceeding correctly.

ADVANCED FORMATTING

NOT FOR PEN INTERFACES

- ⊙ **CONCATENATION** ⚡ ⊙
- ⊙ **ADVANCED FORMATTING** ⚡ ⊙



NOTE

*Please follow the setup procedure carefully for these parameters.
These parameters are not valid for PDF417codes.*

TO CHANGE THE DEFAULT VALUES

- 1.** Read the **Enter Configuration** code ONCE, available at the top of page.
- 2.** Read configuration codes precisely following the numbered procedure given.



= Read the code and follow the procedure given



= Default value



= Only for Enhanced Architecture readers

- 3.** Read the **Exit and Save Configuration** code ONCE, available at the top of page.



CONCATENATION

◆ disable



enable



Permits the concatenation of two codes defined by code type and length. It is possible to set a timeout for the second code reading and to define code transmission if the timeout expires.

The order of transmission is CODE 1-CODE 2.

Define Concatenation**1****Code 1**

code ID



Read the code type from the Code Identifier Table beginning in Appendix B.

code length



Read a number in the range **01-99** from the Hex/Numeric Table.



2

Code 2

code ID



Read the code type from the Code Identifier Table beginning in Appendix B.

code length



Read a number in the range **01-99** from the Hex/Numeric Table.

3

Concatenation Result Code ID

use code 1 ID



use code 2 ID



Since you can concatenate codes from different families, you must select the Code ID character of the resulting code. The Code ID character will be sent in the output message only if it is enabled according to the Code Identifier selection (Datalogic, AIM, or Custom).

**4****Concatenation Timeout**

timeout

Read two numbers in the range **00** to **99**

00= no timeout

01-99 = timeout from 1 to 99 seconds

Define the timeout, which determines the valid waiting period between the two codes, in order to accept concatenation. If the timeout expires, the resulting action will be based on the following selection.

5**Transmission after Timeout**no code transmitted
after timeoutonly code 1 transmitted
(if read) after timeoutonly code 2 transmitted
(if read) after timeouteither code 1 or code 2 transmitted
after timeout

ADVANCED FORMATTING

Advanced formatting has been designed to offer you complete flexibility in changing the format of barcode data **before** transmitting it to the host system. This formatting will be performed when the barcode data meets certain criteria which you will define in the following procedure.

Up to 4 advanced code management formats can be defined and saved in memory. For each format you must complete the entire configuration procedure:

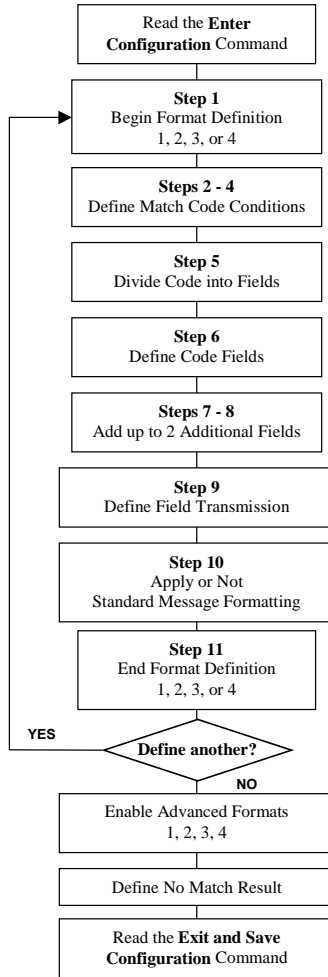



ADVANCED FORMATTING

1

Begin Format Definition

begin Format 1 definition



begin Format 2 definition



begin Format 3 definition



begin Format 4 definition



2

Match Code Type

match code type



Read the above code + the code type to match from the Code Identifier Table in Appendix B.

OR

any code type



3

Match Code Length

Match code length



Read the above code + two numbers in the range **01** to **99** for the exact code length.

OR

any code length





ADVANCED FORMATTING

4

Match with Predefined Characters

no match



OR

match with 1 character



match with a 2-character string



match with a 3-character string



match with a 4-character string



After selecting the predefined match code, read the character(s) from the HEX table. Range of characters = **01-FE**.

Example:

Match code with the 2-character predefined string = "@@".

Read  + 40 + 40

AND

position of first character in predefined string



Read the above code + two numbers in the range **01** to **99** representing the character position in the code where the first character of the predefined string must be found.

Read **00** if the match string can be found in any character position.

ADVANCED FORMATTING



5**Divide Code into Fields**

divide code into fields



Read one number in the range **1** to **5** to divide the code into fields.

6**Define Code Fields**

define code fields

Each code field length can be set by either:

- a) defining a field separator character to be found in the code itself. In this case you can choose to **discard** the code separator character or **include** it as the last character of the field.

OR BY

- b) specifying a specific character length up to the maximum of 99 characters.

OR BY

- c) selecting the last field as variable length (if any).

You must define the same number of fields as selected in step 5, including fields that will not be transmitted.

ADVANCED FORMATTING



DEFINE FIELD 1 BY: EITHER

a) 

field separator



Read the field separator character from the HEX table. Range of characters = **01-FE**.

discard separator



include separator



OR

b) 

field length



Read two numbers in the range **01** to **99** to define the field length.

OR

c)

this is the last field (variable length)



AND

Field 1 Terminators

no field terminators



1 field terminator



2 field terminators



Read the field terminator character(s) from the HEX table.

Valid range of characters for all readers = **01-FE**.

For readers using Wedge interface, all values from **9C** to **FE** send the Space character.

ADVANCED FORMATTING



DEFINE FIELD 2 BY: EITHER

a) 

field separator



Read the field separator character from the HEX table. Range of characters = **01-FE**.

discard separator



include separator



OR

b) 

field length



Read two numbers in the range **01** to **99** to define the field length.

OR

c)

this is the last field (variable length)



AND

Field 2 Terminators

no field terminators



1 field terminator



2 field terminators



Read the field terminator character(s) from the HEX table.

Valid range of characters for all readers = **01-FE**.

For readers using Wedge interface, all values from **9C** to **FE** send the Space character.

ADVANCED FORMATTING



DEFINE FIELD 3 BY: EITHER

a) 

field separator



Read the field separator character from the HEX table. Range of characters = **01-FE**.

discard separator



include separator



OR

b) 

field length



Read two numbers in the range **01** to **99** to define the field length.

OR

c)

this is the last field (variable length)



AND

Field 3 Terminators

no field terminators



1 field terminator



2 field terminators



Read the field terminator character(s) from the HEX table.

Valid range of characters for all readers = **01-FE**.

For readers using Wedge interface, all values from **9C** to **FE** send the Space character.

ADVANCED FORMATTING



DEFINE FIELD 4 BY: EITHER

a) 

field separator



Read the field separator character from the HEX table. Range of characters = **01-FE**.

discard separator



include separator



OR

b) 

field length



Read two numbers in the range **01** to **99** to define the field length.

OR

c)

this is the last field (variable length)



AND

Field 4 Terminators

no field terminators



1 field terminator



2 field terminators



Read the field terminator character(s) from the HEX table.

Valid range of characters for all readers = **01-FE**.

For readers using Wedge interface, all values from **9C** to **FE** send the Space character.

ADVANCED FORMATTING



DEFINE FIELD 5 BY: EITHER

a) 

field separator



Read the field separator character from the HEX table. Range of characters = **01-FE**.

discard separator



include separator



OR

b) 

field length



Read two numbers in the range **01** to **99** to define the field length.

OR

c)

this is the last field (variable length)



AND

Field 5 Terminators

no field terminators



1 field terminator



2 field terminators



Read the field terminator character(s) from the HEX table.

Valid range of characters for all readers = **01-FE**.

For readers using Wedge interface, all values from **9C** to **FE** send the Space character.



ADVANCED FORMATTING

7

First Additional Fixed Field

no fixed field



1 character fixed field



2 character fixed field



3 character fixed field



4 character fixed field



5 character fixed field



6 character fixed field



After selecting **one** of the Additional Fixed Field codes, read the corresponding character(s) from the HEX table. Range of characters = **01-FE**.

Example:

4 Character Fixed Field

 $+ 4D + 41 + 49 + 4E = \text{MAIN}$



ADVANCED FORMATTING

8

Second Additional Fixed Field

no fixed field



1 character fixed field



2 character fixed field



3 character fixed field



4 character fixed field



5 character fixed field

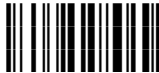

6 character fixed field



After selecting **one** of the Additional Fixed Field codes, read the corresponding character(s) from the HEX table. Range of characters = **01-FE**.

Example:

3 Character Fixed Field

 $+ 53 + 45 + 54 = \text{SET}$

ADVANCED FORMATTING



9

Field Transmission

number of fields to transmit



Read one number in the range 1 to 7 for the number of fields to transmit. **Include only fields to be transmitted.**

Field Order Transmission

Read the codes corresponding to the fields to transmit in the order in which they are to be transmitted, see example.

field 1



field 3



field 5



additional field 2



field 2



field 4



additional field 1



Example:

The barcode is divided into 2 defined fields plus 1 additional fixed field.

Transmit in the order: Field 2, Additional Field 1, Field 1.

Number of Fields



ADVANCED FORMATTING



10**Standard Formatting**

do not apply standard formatting



apply standard formatting



After performing Advanced Formatting on the barcode read, Standard Formatting (Headers, Code Length, Code ID, and Terminators) can be applied to the message to be transmitted.

11**End Format Definition**

end Format 1 definition



end Format 2 definition



end Format 3 definition



end Format 4 definition





ADVANCED FORMATTING

Enable Advanced Format

◆ no Advanced Formats enabled



Advanced Format 1

enable



disable



Advanced Format 2

enable



disable



Advanced Format 3

enable



disable



Advanced Format 4

enable



disable





No Match Result

clear data - no transmission



transmit data using standard format



This selection determines the action to be taken when codes read do not conform to the advanced format requisites (no match).

- Codes not matching can be ignored, cleared from memory and not transmitted.
- Codes not matching can be transmitted using the Standard formatting (Headers, Code Length, Code ID, and Terminators).

4 REFERENCES

4.1 RS232 PARAMETERS

4.1.1 Handshaking

Hardware handshaking: (RTS/CTS)

The RTS line is activated by the decoder before transmitting a character. Transmission is possible only if the CTS line (controlled by the Host) is active.

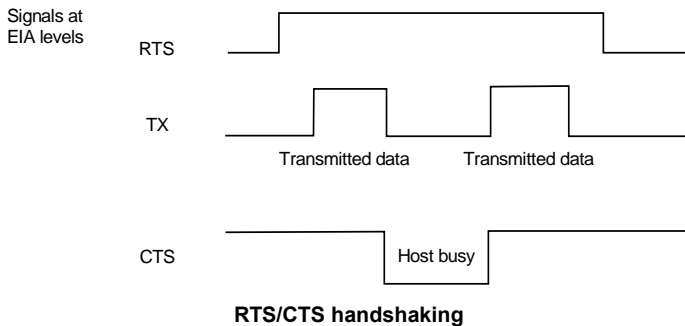

Software handshaking: (XON/XOFF)

During transmission, if the Host sends the XOFF character (13 Hex), the decoder interrupts the transmission with a maximum delay of one character and only resumes when the XON character (11 Hex) is received.

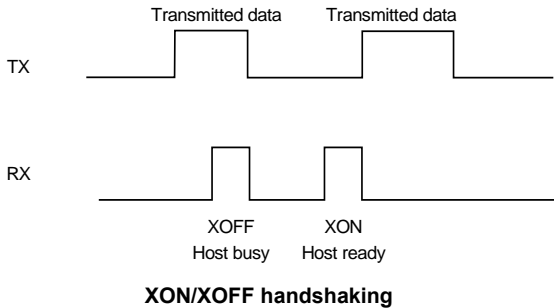

4.1.2 ACK/NACK Protocol

This parameter sets a transmission protocol in which the Host responds to the reader after every code transmitted. The Host sends an ACK character (06 HEX) in the case of good reception or the NACK character (15 HEX) requesting re-transmission, in the case of bad reception.

If the reader does not receive an ACK or NACK, transmission is ended after the RX Timeout (see par. 4.1.4).

Selection of the ACK/NACK protocol automatically disables FIFO buffering see par. 4.1.3.

4.1.3 FIFO

This parameter determines whether data (barcodes) are buffered on a First In First Out basis allowing faster data collection in certain cases for example when using slow baud rates and/or hardware handshaking.

If the FIFO buffering is enabled, codes are collected and sent out on the serial line in the order of acquisition. About 800 characters for Enhanced Architecture readers and 185 characters for Standard Architecture readers can be collected (buffer full), after which the reader signals an error and discards any further codes until the transmission is restored.

If the FIFO buffering is disabled, each code must be transmitted before another one can be read.

Selection of FIFO buffering automatically disables the ACK/NACK protocol, see par. 4.1.2, and Sleep State, see par. 4.4.2.

4.1.4 RX Timeout

When the RS232 interface is selected, the Host can be used to configure the device by sending it command strings (see appendix A).

This parameter can be used to automatically end data reception from the Host after the specified period of time.

If no character is received from the Host, after the timeout expires, any incomplete string (any string not terminated by <CR>) is flushed from the device buffer.

4.2 PEN PARAMETERS

4.2.1 Minimum Output Pulse

This parameter sets the duration of the output pulse corresponding to the narrowest element in the barcode. In this way the code resolution is controlled by the signal sent to the decoder, independently of the physical resolution of the code read.

The shortest pulse (200 μ s) corresponds to high-resolution code emulation and therefore a shorter transfer speed to the decoder (for decoders able to work on high-resolution codes). Likewise, longer pulses correspond to low-resolution code emulation and therefore a longer transfer time to the decoder.

4.2.2 Overflow

This parameter generates a white space before the first bar and after the last bar of the code. The selections are as follows:

- narrow = space 10 times the minimum output pulse.
- medium = space 20 times the minimum output pulse.
- wide = space 30 times the minimum output pulse.

4.2.3 Output and Idle Levels

The following state diagrams describe the different output and idle level combinations for Pen emulation:

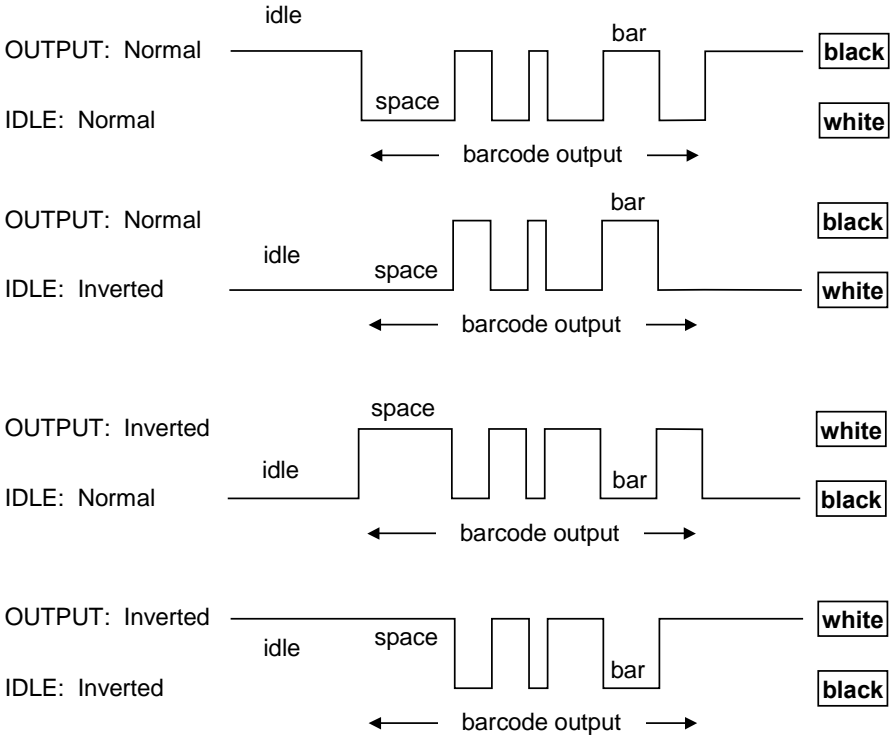

Output and Idle Levels

4.3 DATA FORMAT

4.3.1 Header/Terminator Selection

The header/terminator selection is not effected by the reading of the restore default code. In fact, header and terminator default values depend on the interface selection:

RS232: no header, terminator CR-LF

WEDGE: no header, terminator ENTER

These default values are always restored through the reading of RS232 or WEDGE interface selection code, see chapter 2.

For the WEDGE interface, the following extended keyboard values can also be configured:

EXTENDED KEYBOARD TO HEX CONVERSION TABLE				
HEX	IBM AT IBM 3153 APPLE ADB	IBM XT	IBM 31xx, 32xx, 34xx, 37xx	Wyse Digital
83	ENTER	ENTER	FIELD EXIT	RETURN
84	TAB	TAB	TAB	TAB
85	F1	F1	F1	F1
86	F2	F2	F2	F2
87	F3	F3	F3	F3
88	F4	F4	F4	F4
89	F5	F5	F5	F5
8A	F6	F6	F6	F6
8B	F7	F7	F7	F7
8C	F8	F8	F8	F8
8D	F9	F9	F9	F9
8E	F10	F10	F10	F10
8F	F11	ESC	F11	F11
90	F12	BACKSPACE	F12	F12
91	HOME	HOME	ENTER	F13
92	END	END	RESET	F14
93	PG UP	PG UP	INSERT	F15
94	PG DOWN	PG DOWN	DELETE	F16
95	↑	↑	FIELD -	UP
96	↓	↓	FIELD +	DOWN
97	←	←	ENTER (Paddle)	LEFT
98	→	→	PRINT	RIGHT
99	ESC	ESC		ESC
9A	CTRL (Right)	CTRL (Right)		CTRL (Right)
9B	Euro	Space	Space	Space

NOTE: The highlighted values refer only to Enhanced Architecture configurations.

For Standard Architecture readers valid characters are in the range **00-7F** (RS232) and **00-9B** (WEDGE). For Enhanced Architecture readers valid characters are in the range **00-FE**; when using Wedge interface for Enhanced Architecture readers, all values from **9C** to **FE** send the Space character.

4.3.2 Set Custom Extended Header/Terminator Keys

The extended Header/Terminator keys for **Wedge Interface users** can be customized by defining them through a simple keyboard setting procedure.

For example, the Numeric Keypad keys can be set for use as Headers or Terminators by substituting the default extended keys using this procedure.

The type of computer or terminal must be selected before activating the keyboard setting command.

Press and release a key to set it.

Some characters may require more than one key pressed simultaneously during normal use (refer to the manual of your PC or terminal for keyboard use). The exact sequence must be indicated to the reader in this case pressing and releasing the different keys.

Example:

If one has to press the "Shift" and "4" keys simultaneously on the keyboard to transmit the character "\$" to the video, to set the "\$", press and release "Shift" then press and release "4".

Each pressed and released key must generate an acoustic signal on the reader, otherwise repress the key. Never press more than one key at the same time, even if this corresponds to the normal use of your keyboard.

Press "Backspace" to correct a wrong key entry. In this case the reader emits 2 beeps.

Note: "CAPS LOCK" and "NUM LOCK" must be off before starting the keyboard setting procedure. "SHIFT" must be repressed for each character and cannot be substituted by "CAPS LOCK".



Set Custom Extended Header/Terminator Keys



Read the code above.

- If the first 4 KEYS (Shift, Alt, Ctrl, and Backspace) are not available on your keyboard, you can only substitute them with keys not used, or substitute them with each other.
- Keys 5 to 28 must be defined

Press the desired keys in the following order:

The reader signals the end of the procedure with 2 beeps indicating the keys have been registered.

CUSTOM EXTENDED KEYBOARD SETTING TABLE		
		Custom
Order	HEX	KEY
01	-	Shift
02	-	Alt
03	-	Ctrl
04	-	Backspace
05	83	
06	84	
07	85	
08	86	
09	87	
10	88	
11	89	
12	8A	
13	8B	
14	8C	
15	8D	
16	8E	
17	8F	
18	90	
19	91	
20	92	
21	93	
22	94	
23	95	
24	96	
25	97	
26	98	
27	99	
28	9A	

4.4 POWER SAVE

4.4.1 Illuminator/Laser Driver

To reduce maximum power consumption, this command assures that the **Illuminator** (for CCD devices), and the **beeper** are not on simultaneously.

For scanners the **Laser** and the **beeper** are not on simultaneously.

4.4.2 Sleep State (*only devices with button/trigger*)

This mode allows the μP in the reader to enter a "Sleep" state for minimum power consumption. This command is only valid when hardware trigger type is selected.

Before entering Sleep mode, the following are verified:

- no commands coming from Host
- no data being transmitted to Host
- Enter Sleep Timeout ended (see par.4.4.3)

To exit Sleep mode press the trigger.

Enabling the Sleep state implements Standby mode for CCD devices, see par. 4.4.4, and disables FIFO, see par. 4.1.3.

4.4.3 Enter Sleep Timeout

For readers that have the Sleep state enabled, this timeout determines when the reader will enter this state.

4.4.4 Standby (*only CCD devices with button/trigger*)

If this command is enabled, part of the CCD circuitry shuts down (Standby), in order to optimize low power consumption when not reading. When the trigger is pressed this circuitry powers up. This mode causes a minor delay of about 100 ms before the reader is ready.

Disabling Standby automatically disables Sleep State, see par. 4.4.2.

4.5 READING PARAMETERS

4.5.1 Trigger Signal

Trigger signal is useful to determine the modality of the reader ON state for readers with trigger when hardware trigger is selected:

- trigger level: the reader goes ON when the trigger is pressed and goes OFF when it is released
- trigger pulse: the reader goes ON at the first trigger press and goes OFF only at a second press

4.5.2 Trigger-Off Timeout

When this timeout is selected, the reader turns OFF automatically after the desired period of time.

4.5.3 Reads per Cycle

In general, a **reading cycle** corresponds to the ON + OFF times of a device. The resulting effects of this parameter on code reading depend on other related configuration conditions. Here are the definitions of ON and OFF times.

- For readers using the software trigger parameter (FLASH MODE), a reading cycle corresponds to the *flash on* + *flash off* times. Code reading takes place during the *flash on* time.
- For readers using the *hardware trigger* parameter, a reading cycle corresponds to a trigger press (ON) + one of the following OFF events:
 - trigger release (for *trigger active level*)
 - a second trigger press (for *trigger active pulse*)
 - trigger-off timeout* (see par. 4.5.2).

When **one read per cycle** is selected, the device decodes only one code during the ON period and immediately turns the reader OFF. It is only possible to read another code when the next ON time occurs.

In **multiple reads per cycle**, the ON period is extended so that the device can continue decoding codes until an OFF event occurs. For software trigger mode, the *flash on* period is immediately reset after each read and therefore extended. If another code is decoded before the reset *flash on* period expires, it is again reset

and the effect is that the device remains ON, decoding codes until the *flash on* or *timeout* period expires.

The Safety Time parameter should be used in this case to avoid unwanted multiple reading of the same code, see par. 4.5.4.

4.5.4 Safety Time

Safety time prevents the device from immediately decoding the same code more than once. Same code consecutive reading can be disabled requiring the reader to be removed from the code (no decoding) for at least 400 ms, or a timeout can be set up to 9.9 seconds before the decoder will accept the same code. Reading is immediate if the code changes.

4.6 DECODING PARAMETERS



CAUTION

These parameters are intended to enhance the decoding capability of the reader for particular applications. Used incorrectly, they can degrade the reading performance or increase the possibility of a decoding error.

4.6.1 Ink-Spread

The ink-spread parameter allows the decoding of codes which are not perfectly printed because the page texture tends to absorb the ink.

4.6.2 Overflow Control

The overflow control parameter can be disabled when decoding codes printed on small surfaces, which don't allow the use of an overflow space.





This command does not effect code families 2/5, Code 128 and Code 93.

4.6.3 Interdigit Control

The interdigit control parameter verifies the interdigit spacing for code families Code 39 and Codabar.

4.7 CONFIGURATION EDITING COMMANDS

The following commands carry out their specific function and then exit the configuration environment.

Command	Description
 \$+\$*	Restore system default configuration (see the relative Quick Reference Manual for default settings)
 \$+\$!	Transmit the Software release
 \$+\$&	 For Enhanced Architecture readers the device configuration is transmitted in ASCII format. This command is not effective with the Pen emulation interface.

4.8 CONFIGURATION COPY COMMAND

Procedure:

- ① Connect the **master** (correctly configured reader) and the **slave** (reader to be configured) together through two RS232 serial interface cables and external power supply. Accessory cables and power supply are available from your Datalogic distributor to provide this connection.

RS232 Cables: CAB363 & CAB364 or CAB320 & CAB328

Power Supply: PG5

- ② Using the slave device, read the Restore Default barcode and then the RS232 interface barcode from paragraphs 2.1 and 2.2 of this manual or from the Quick Reference Manual.
- ③ With the master device, read the Configuration Copy barcode below.

Copy Configuration



\$+ZZ0\$-

The configuration will be copied from the master to the slave device. The slave device signals the end of the procedure with a series of beeps.

Note: The master device can be configured for any interface.

A HOST CONFIGURATION STRINGS

In this section we provide a description of how to modify the device configuration using serial strings sent from the Host.

This method requires the RS232 interface.

The device configuration can be changed by receiving commands from the Host through the serial interface. When this method is used, the programming sequence format is the following:

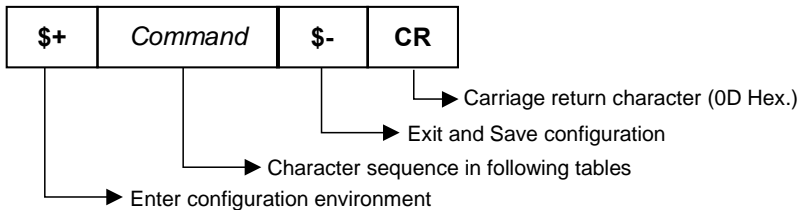

Example:

Multiple command programming sequence:

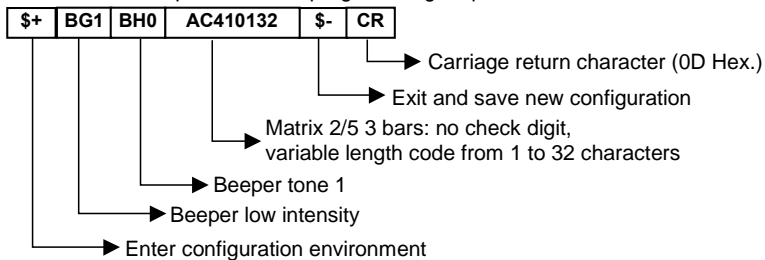

Each configuration parameter setting removes the condition previously active for that parameter.



NOTE

The device buffer for Standard Architecture readers can contain a maximum of 60 characters; the device buffer for Enhanced Architecture readers can contain about 400 characters. If your programming string goes over this value, you must split it into separate groups and send each group after a delay of at least 3 seconds to give the reader time to empty the buffer and interpret the commands.

SERIAL CONFIGURATION STRINGS

ENTER/EXIT CONFIGURATION COMMANDS	
DESCRIPTION	STRING
Enter Configuration	\$+
Exit and Save Configuration	\$-
Restore Default	\$*
Transmit Software Release (not for PEN emulation)	\$!

These commands do not require \$-.

INTERFACE SELECTION	
DESCRIPTION	STRING
RS232	CP0
WEDGE for IBM AT	CP500
for IBM Terminals: 31xx, 32xx, 34xx, 37xx; make-break keyboard	CP501
for IBM Terminals: 31xx, 32xx, 34xx, 37xx; make-only keyboard	CP502
Keyboard Type for IBM Terminals	typewriter
31xx, 32xx, 34xx, 37xx	advanced
for IBM XT	CP503
for IBM Terminal 3153	CP504
for IBM PC Notebook	CP505
for IBM SURE1	CP506
☀ for IBM AT - ALT mode	CP507
☀ for IBM PC Notebook - ALT mode	CP508
☀ for Wyse Terminal - ANSI Keyboard	CP509
☀ for Wyse Terminal - PC Keyboard	CP510
☀ for Wyse Terminal - ASCII Keyboard	CP511
☀ for Wyse Terminal - VT220 style Keyboard	CP514
☀ for Digital Terminals VT2xx/3xx/4xx	CP512
☀ for Apple ADB Bus	CP513
PEN EMULATION	CP6

RS232		
DESCRIPTION	STRING	
Baud rate	150	CD0
	300	CD1
	600	CD2
	1200	CD3
	2400	CD4
	4800	CD5
	9600	CD6
	☀ 19200	CD7
	☀ 38400	CD8
Parity	none	CC0
	even	CC1
	odd	CC2









RS232 (continued)		
Data bits	7	CA0
	8	CA1
	9	CA2
Stop bits	1	CB0
	2	CB1
Handshaking	disable	CE0
	RTS/CTS	CE1
	XON/XOFF	CE2
	RTS always ON	CE3
ACK/NACK Protocol	disable	CF0
	enable	CF3
FIFO	disable	EC0
	enable	EC1
Inter-character delay (<i>ms</i>)		CK00 - CK99
RX Timeout (<i>100 ms</i>)		CL00 - CL99
Serial Trigger Lock	disable	CR0
	enable	CR1a b

a = Hex value of the ASCII character from **00** to **7F** for Standard Architecture readers and from **00** to **FE** for Enhanced Architecture readers which enables the device trigger;

b = Hex value of the ASCII character from **00** to **7F** for Standard Architecture readers and from **00** to **FE** for Enhanced Architecture readers which inhibits the device trigger;

WEDGE		
DESCRIPTION		STRING
Keyboard nationality	Belgian	FJ7
	English	FJ4
	French	FJ2
	German	FJ3
	Italian	FJ1
	Spanish	FJ6
	Swedish	FJ5
	USA	FJ0
Caps Lock	caps Lock ON	FE1
	caps Lock OFF	FE0
☀ Num Lock	Toggle Num Lock	FL1
	Num Lock Unchanged	FL0
Delays	Inter-Character (<i>ms</i>)	CK00 - CK99
	Inter-Code (<i>s</i>)	FG00 - FG99
Control Character Emulation	CTRL + Shift + Key	FO0
	Ctrl + Key	FO1

PEN		
DESCRIPTION		STRING
Operating mode	interpret (does not require \$+ or \$-)	\$]
	transparent (does not require \$+ or \$-)	[\$
Minimum output pulse	200µs	DG0
	400µs	DG1
	600µs	DG2
	800µs	DG3
	1 ms	DG4
	1.2 ms	DG5
Conversion to Code 39	disable	DA0
	enable	DA1
Output level	normal	DD0
	inverted	DD1
Idle level	normal	DE0
	inverted	DE1
Overflow	narrow overflow	DH0
	medium overflow	DH1
	wide overflow	DH2

DATA FORMAT		
NOT FOR PEN EMULATION INTERFACES		
DESCRIPTION		STRING
Code Identifier	disable	EB0
	Datalogic standard	EB1
	AIM standard	EB2
	Custom	EB3
Custom Code Identifier		EHabc
Headers	no header	EA00
	one character	EA01x
	two characters	EA02xx
	three characters	EA03xxx
	four characters	EA04xxxx
	 five characters	EA05xxxxx
	 six characters	EA06xxxxxx
	 seven characters	EA07xxxxxxxx
 eight characters	EA08xxxxxxxxx	
Terminators	no terminator	EA10
	one character	EA11x
	two characters	EA12xx
	three characters	EA13xxx
	four characters	EA14xxxx
	 five characters	EA15xxxxx
	 six characters	EA16xxxxxx
	 seven characters	EA17xxxxxxxx
 eight characters	EA18xxxxxxxxx	

a = ASCII character.

b, c, x = HEX values representing an ASCII character.

a = ASCII character of the DATALOGIC STANDARD Code Identifier from the table on page 29.

b = Hex value of the first Custom Code Identifier character from **00** to **7F** for Standard Architecture readers and from **00** to **FE** for Enhanced Architecture readers;
FF = disable Code Identifier

c = Hex value of the second Custom Code Identifier character from **00** to **7F** for Standard Architecture readers and from **00** to **FE** for Enhanced Architecture readers;
FF = disable second character of Custom Code Identifier

x = Standard Architecture
for RS232: Hex value from **00** to **7F**
for Wedge: Hex value from **00** to **9B**

Enhanced Architecture
Hex value from **00** to **FE**
for Wedge: values from **9C** to **FE** send the Space character

DATA FORMAT (continued)		
NOT FOR PEN EMULATION INTERFACES		
DESCRIPTION		STRING
☀ Code Length Tx	not transmitted	EE0
	transmitted	EE1
	transmitted in 4-digit format	EE2
☀ Field Adjustment	disabled	EF0
	right addition	EFa0d
	left addition	EFa1d
	right deletion	EFa2d
	left deletion	EFa3d
☀ Field Adjustment Character		EGe
☀ Character Replacement	disable character replacement	E00
	first character replacement	E01afg
	second character replacement	E02afg
	third character replacement	E03afg

a = ASCII character.

d = a number from the Hex/Numeric Table.

e, f, g = HEX values representing an ASCII character.

a = ASCII character of the DATALOGIC STANDARD Code Identifier from the table on page 29.

d = a number in the range **01 – 32** from the Hex/Numeric Table

e = Hex value from **00 to FE**

f = Hex value of the character to be replaced from **00 to FE**

g = Hex value of the new character to insert from **00 to FE**

FF = replace with no new character (remove character)

POWER SAVE		
DESCRIPTION		STRING
Illuminator/Laser Driver	no change before beep	BN0
	off before beep	BN1
Sleep State	disable	BQ0
	enable	BQ1
Enter Sleep Timeout (<i>100 ms</i>)		BR00-BR99
Standby	enable	BM0
	disable	BM1

READING PARAMETERS		
DESCRIPTION		STRING
Trigger Type	software trigger	BK0
	hardware trigger	BK1
Trigger Signal	trigger active level	BA0
	trigger active pulse	BA1
Trigger-off Timeout (s)		BD00 - BD99
FLASH ON (100 ms)		BB001 - BB099
FLASH OFF (100 ms)		BB101 - BB199
Reads per Cycle	one read	BC0
	multiple reads	BC1
Safety Time (100 ms)		BE00 - BE99
Beeper Intensity	beeper off	BG0
	low intensity	BG1
	medium intensity	BG2
	high intensity	BG3
Beeper Tone	tone 1	BH0
	tone 2	BH1
	tone 3	BH2
	tone 4	BH3
Software Focus Level	factory focus level	BL0
	high resolution	BL1
	med-high resolution	BL2
	med-low resolution	BL3
	low resolution	BL4
Software Focus Range	factory focus range	BS0
	long range only	BS1

DECODING PARAMETERS		
DESCRIPTION		STRING
Ink-spread	disable	AX0
	enable	AX1
Overflow control	disable	AW1
	enable	AW0
Interdigit control	disable	AV0
	enable	AV1
Decoding Safety	one read	ED0
	two reads	ED1
	three reads	ED2
	four reads	ED3
 PuzzleSolver™	disable	AU0
	enable	AU1

CODE SELECTION			
DESCRIPTION		STRING	
DISABLE ALL FAMILY CODES		AZ0	
EAN/UPC	disable EAN/UPC family		AA0
	EAN 8/EAN 13/UPC A/UPC E	without ADD ON	AA1
		with ADD ON	AA5
		with and without ADD ON	AA8
	EAN 8/EAN 13	without ADD ON	AA3
		with ADD ON 2 ONLY	AAK
		with ADD ON 5 ONLY	AAL
		with ADD ON 2 AND 5	AA6
	UPC A/UPC E	without ADD ON	AA4
		with ADD ON 2 ONLY	AAM
		with ADD ON 5 ONLY	AAN
		with ADD ON 2 AND 5	AA7
	EAN 8 check digit transmission	disable	AAG0
		enable	AAG1
	EAN 13 check digit transmission	disable	AAH0
		enable	AAH1
	UPC A check digit transmission	disable	AAI0
		enable	AAI1
	UPC E check digit transmission	disable	AAJ0
		enable	AAJ1
conversions	UPC E to UPC A	AAA	
	UPC E to EAN 13	AAB	
	UPC A to EAN 13	AAC	
	EAN 8 to EAN 13	AAD	

CODE SELECTION (continued)			
DESCRIPTION		STRING	
	ISBN Conversion codes	enable ISBN	AP1
		enable ISSN	AP2
		enable ISBN and ISSN	AP3
		disable ISBN and ISSN	AP0
Code 39	disable Code 39 family		AB0
	Standard	no check digit control	AB11
		check digit control and transmission	AB12
		check digit control without transmission	AB13
	Full ASCII	no check digit control	AB21
		check digit control and transmission	AB22
		check digit control without transmission	AB23
	CIP 39		AB3
Code 32		AB4	
code length		AB*xxxx	
2/5	disable Code 2/5 family		AC0
	Interleaved 2/5	no check digit control	AC11xxxx
		check digit control and transmission	AC12xxxx
		check digit control without transmission	AC13xxxx
	Normal 2/5 5 bars	no check digit control	AC21xxxx
		check digit control and transmission	AC22xxxx
		check digit control without transmission	AC23xxxx
	Industrial 2/5 (IATA)	no check digit control	AC31xxxx
		check digit control and transmission	AC32xxxx
		check digit control without transmission	AC33xxxx
	Matrix 2/5 3 bars	no check digit control	AC41xxxx
		check digit control and transmission	AC42xxxx
		check digit control without transmission	AC43xxxx
	CIP/HR		AC5

xxxx = ASCII numbers that define the code length where:

- First 2 digits = minimum acceptable code length.
- Second 2 digits = maximum acceptable code length.

The minimum code length must always be less than or equal to the maximum. The maximum code lengths are **99** characters.

Examples:

0132 = variable length from 1 to 32 digits in the code.

1010 = 10 digit code length only.

CODE SELECTION (continued)				
DESCRIPTION		STRING		
Codabar	disable Codabar family		AD0	
	Standard	no start/stop character equality control nor transmission	AD111	
		no start/stop character equality control but transmission	AD112	
		start/stop character equality control but no transmission	AD121	
		start/stop character equality control and transmission	AD122	
		ABC Codabar	no start/stop character equality control but transmission	AD212
	☀	Codabar ABC forced concatenation		AD232
		code length		AD*xxxx
		start/stop character case in transmission	lower case	ADA0
			upper case	ADA1
Code 128	disable Code 128 family		AI0	
	enable Code 128 - control without transmission of check digit		AI11	
	enable EAN 128 - control without transmission of check digit		AI21	
	☀	ISBT 128	enable ISBT 128	AI31
	define EAN 128 separator character		EPx	
		EAN 128 separator character	disable	Aa0
			enable	Aa1
		add first GS in EAN 128	disable	EQ0
	enable		EQ1	
Code 93	disable Code 93 family		AK0	
	enable Code 93 - control without transmission of check digit		AK1	
☀	Codablock-A	disable	AO0	
		enable	AO1	
☀	Codablock-F	disable the family	AN0	
		enable Standard	AN1	
		enable EAN	AN2	

x = for RS232: Hex value from **00** to **7F**

x = for WEDGE: Hex value from **00** to **9B**

xxxx = ASCII numbers that define the code length where:

- First 2 digits = minimum acceptable code length.
- Second 2 digits = maximum acceptable code length.

The minimum code length must always be less than or equal to the maximum. The maximum code lengths are **99** characters.

Examples:

0132 = variable length from 1 to 32 digits in the code.

1010 = 10 digit code length only.

CODE SELECTION (continued)		
DESCRIPTION		STRING
☀ MSI	disable the family	AE0
	no check	AE1
	MOD10 no tx	AE2
	MOD10 with tx	AE3
	MOD11-MOD10 no tx	AE4
	MOD11-MOD10 with tx	AE5
	MOD10-MOD10 no tx	AE6
	MOD10-MOD10 with tx	AE7
☀ Plessey	disable the family	AF0
	Standard no check	AF11
	Standard check - with tx	AF12
	Standard check - no tx	AF13
	Anker no check	AF21
	Anker check - with tx	AF22
	Anker check - no tx	AF23
☀ Telepen	disable the family	AL0
	Numeric no check	AL11
	Numeric check - with tx	AL12
	Numeric check - no tx	AL13
	Alpha no check	AL21
	Alpha check - with tx	AL22
	Alpha check - no tx	AL23
☀ Delta IBM	disable the family	AH0
	no check	AH1
	Type 1 check	AH2
	Type 2 check	AH3
☀ Code 11	disable the family	AG0
	no check	AG1
	Type C with tx	AG21
	Type C no tx	AG22
	Type K with tx	AG31
	Type K no tx	AG32
	Type C and K with tx	AG41
	Type C and K no tx	AG42
☀ Code 16K	disable	AJ0
	enable	AJ1
☀ Code 49	disable	AM0
	enable	AM1
☀ PDF417	disable	AR0
	enable	AR1

B CODE IDENTIFIER TABLE

2/5 Interleaved



2/5 Industrial

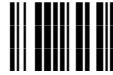

2/5 normal 5 bars



2/5 matrix 3 bars



EAN 8



EAN 13



UPC A



UPC E



EAN 8 with 2 ADD ON



EAN 8 with 5 ADD ON



EAN 13 with 2 ADD ON



EAN 13 with 5 ADD ON



UPC A with 2 ADD ON



UPC A with 5 ADD ON



UPC E with 5 ADD ON



Code 39 Full ASCII



ABC CODABAR



EAN 128



CIP/39



Code 32



UPC E with 2 ADD ON



Code 39



CODABAR



Code 128



Code 93



CIP/HR

ISBT 128 

CODABLOCK-A 



CODABLOCK-F Standard 



CODABLOCK-F EAN 



MSI 

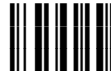

Plessey Anker 



Plessey Standard 



Delta IBM 



Telepen 



Code 16K 



Code 11 



PDF417 



Code 49 



C HEX AND NUMERIC TABLE

**OPEN THIS PAGE TO READ THE DESIRED
HEX AND NUMERIC SELECTIONS**

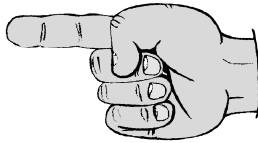

CHARACTER TO HEX CONVERSION TABLE

char	hex	char	hex	char	hex
NUL	00	*	2A	U	55
SOH	01	+	2B	V	56
STX	02	,	2C	W	57
ETX	03	-	2D	X	58
EOT	04	.	2E	Y	59
ENQ	05	/	2F	Z	5A
ACK	06	0	30	[5B
BEL	07	1	31	\	5C
BS	08	2	32]	5D
HT	09	3	33	^	5E
LF	0A	4	34	^	5F
VT	0B	5	35	~	60
FF	0C	6	36	a	61
CR	0D	7	37	b	62
SO	0E	8	38	c	63
SI	0F	9	39	d	64
DLE	10	:	3A	e	65
DC1	11	;	3B	f	66
DC2	12	<	3C	g	67
DC3	13	=	3D	h	68
DC4	14	>	3E	i	69
NAK	15	?	3F	j	6A
SYN	16	@	40	k	6B
ETB	17	A	41	l	6C
CAN	18	B	42	m	6D
EM	19	C	43	n	6E
SUB	1A	D	44	o	6F
ESC	1B	E	45	p	70
FS	1C	F	46	q	71
GS	1D	G	47	r	72
RS	1E	H	48	s	73
US	1F	I	49	t	74
SPACE	20	J	4A	u	75
!	21	K	4B	v	76
"	22	L	4C	w	77
#	23	M	4D	x	78
\$	24	N	4E	y	79
%	25	O	4F	z	7A
&	26	P	50	{	7B
'	27	Q	51		7C
(28	R	52	}	7D
)	29	S	53	~	7E
		T	54	DEL	7F

HEX / NUMERIC TABLE



Cancels an incomplete configuration sequence



90ACC1854